



Mid Trunnion Underbody Hoists



Capacity of rams is calculated assuming a free flowing load, a minimum tipping angle of 50° and includes body weight.

For specific capacities against known operating conditions contact Truck Hydraulic Solutions.

Maximum lifting capacity calculated at 170 bar.

* Measurement includes 20 mm pull out required for mounting

30° MAX BALL ANGLE

Please note: When replacing a cylinder in a twin underbody application - the cylinders must be of the same batch date, due to modifications made to design over time.

MODEL	NO OF STAGES	LIFT (mm)	LIFT CAPACITY 50° TIP (TONNES)			* CLOSED HEIGHT (mm)	WEIGHT (kg)	OIL (LITRES)	MOUNT	STAGE DIAMETER (mm)								
			NOM	MAX	IDEAL PIVOT					30	46	61	76	91	107	126	145	165
SINGLE UNDERBODY										30	46	61	76	91	107	126	145	165
6002S	6	840	4	6.5	1010	315	23	3.6	40	●	●	●	●	●	●			
6003S	6	1005	4	6.5	1190	355	26	4.5	40	●	●	●	●	●	●			
3063S	4	790	5	8.5	950	380	21	3.2	35		●	●	●	●				
3065S	4	1050	5	8.5	1260	445	26	4.3	35		●	●	●	●				
3092S	5	1040	5	8.5	1190	395	29	5	40		●	●	●	●	●			
3093S	5	1190	5	8.5	1425	425	31	6	40		●	●	●	●	●			
3094S	5	1490	5	8.5	1785	485	35	7.5	40		●	●	●	●	●			
6008S	6	1480	5	8.5	1785	440	46	8.9	45		●	●	●	●	●	●		
6009S	6	1780	5	8.5	2140	490	51	11.2	45		●	●	●	●	●	●		
8004S	8	1940	7	11.5	2300	462	78	19.5	50		●	●	●	●	●	●	●	●
TWIN UNDERBODY										30	46	61	76	91	107	126	145	165
3095S	5	2140	5	8.5	2550	615	45	10.8	40		●	●	●	●	●			
3096S	5	2490	5	8.5	2960	685	50.5	12.4	40		●	●	●	●	●			
6012S	6	2977	5	8.5	3500	690	71	19	45		●	●	●	●	●	●		
3047S	4	1510	7	11.5	1785	572	43	8.7	40			●	●	●	●			
3048S	4	1710	7	11.5	2025	622	46	10	40			●	●	●	●			
3049S	4	1990	7	11.5	2380	692	51	11.5	40			●	●	●	●			
3052S	5	1230	9	15	1490	450	45	9	45			●	●	●	●	●		
3053S	5	1480	9	15	1785	500	53	11	45			●	●	●	●	●		
3055S	5	2130	9	15	2550	630	67	15.5	45			●	●	●	●	●		
3356S	5	2480	9	15	2975	700	75	18	45			●	●	●	●	●		
HEAVY SERIES										68	88	107	126	145	165			
4058S	6	1540	14	24	1890	478	82	18.5	50	●	●	●	●	●	●			
4059S	6	1810	14	24	2210	523	89	21.5	50	●	●	●	●	●	●			
4060S	6	2225	14	24	2675	593	102	25.9	50	●	●	●	●	●	●			
4062S	6	2910	14	24	3570	713	125	34.6	50	●	●	●	●	●	●			
5010S	5	3490	14	24	4165	935	133	46	50		●	●	●	●	●			

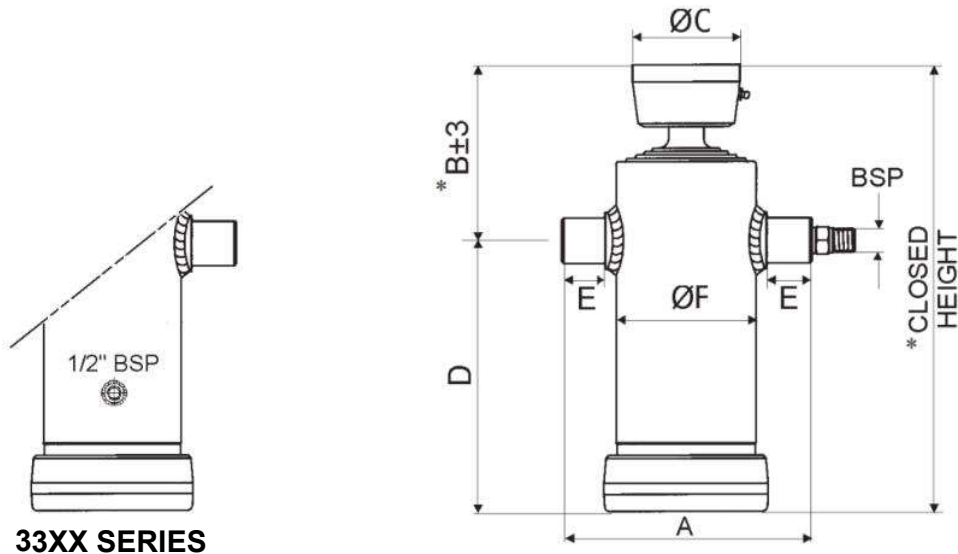

33XX SERIES

MODEL	A	*B	C	D	E	F	* CLOSED HEIGHT	BSP	SEAL KIT
6002S	230	160	112	155	40	124	315	1/2"	SKCY013
6003S	230	170	112	185	40	124	355	1/2"	SKCY013
3063S	215	160	112	220	40	112	380	1/2"	SKCY003
3065S	215	165	112	280	40	112	445	1/2"	SKCY003
3092S	230	170	112	225	40	124	395	1/2"	SKCY006
3093S	230	170	112	255	40	124	425	1/2"	SKCY006
3094S	230	170	112	315	40	124	485	1/2"	SKCY006
3095S	230	170	112	445	40	124	615	1/2"	SKCY006
3096S	230	170	112	515	40	124	685	1/2"	SKCY006
6008S	265	175	112	265	45	152	440	1/2"	SKCY031
6009S	265	175	112	315	45	152	490	1/2"	SKCY031
6012S	265	175	112	515	45	152	690	1/2"	SKCY031
8004S	320	270	112	192	45	190	462	3/4"	SKCY035
3047S	230	177	95	395	40	124	572	1/2"	SKCY004
3048S	230	177	95	445	40	124	622	1/2"	SKCY004
3049S	230	177	95	515	40	124	692	1/2"	SKCY004
3052S	265	185	95	265	45	152	450	1/2"	SKCY005
3053S	265	185	95	315	45	152	500	1/2"	SKCY005
3055S	265	185	95	445	45	152	630	1/2"	SKCY005
3356S	265	185	95	515	45	152	700	1/2"	SKCY005
4058S	320	268	107	210	45	190	478	3/4"	SKCY012
4059S	320	268	107	255	45	190	523	3/4"	SKCY012
4060S	320	268	107	325	45	190	593	3/4"	SKCY012
4062S	320	268	107	445	45	190	713	3/4"	SKCY012
5010S	320	265	107	670	45	190	935	3/4"	SKCY011